

# The Possibility of Determining the Input Parameters for the Discrete Element Method

Jiří ROZBROJ<sup>1)</sup>, Jiří ZEGZULKA<sup>2)</sup>, Lucie JEZERSKÁ<sup>3)</sup>, Jan NEČAS<sup>4)</sup>, David ŽUROVEC<sup>5)</sup>

<sup>1)</sup> Eng.; Ph. D.; VŠB Technical University of Ostrava, Centrum ENET, 17. Listopadu 15/2172, 708 33 Ostrava – Poruba, Czech Republic; email: jiri.rozbroj@vsb.cz

<sup>2)</sup> Prof.; Eng.; Csc.; VŠB Technical University of Ostrava, Centrum ENET, 17. Listopadu 15/2172, 708 33 Ostrava – Poruba, Czech Republic; email: jiri.zegzulka@vsb.cz

<sup>3)</sup> Eng.; Ph. D.; VŠB Technical University of Ostrava, Centrum ENET, 17. Listopadu 15/2172, 708 33 Ostrava – Poruba, Czech Republic; email: lucie.jezerska@vsb.cz

<sup>4)</sup> Eng.; Ph. D.; VŠB Technical University of Ostrava, Centrum ENET, 17. Listopadu 15/2172, 708 33 Ostrava – Poruba, Czech Republic; email: jan.necas@vsb.cz

<sup>5)</sup> Eng.; VŠB Technical University of Ostrava, Centrum ENET, 17. Listopadu 15/2172, 708 33 Ostrava – Poruba, Czech Republic; email: david.zurovec@vsb.cz

DOI: 10.29227/IM-2015-01-14

## Summary

*This article describes measurements of mechanical-physical properties of a particular material, which can be used for validation or calibration of Discrete Element Method (DEM) and definition of basic input parameters or their extents. The validation can be executed by means of a real model of the equipment with which the DEM model is compared. It also explains potential measurement procedures for a real material to determine and verify the input parameter properties for the DEM. The validation material can be of plastic spherical particles, because this shape represents the basic particle for the DEM. Determination of the coefficient of restitution is executed by means of a high-speed camera and subsequent measurement of the particle's movement on a single XY plane. Collection of the measured data is used for identification and selection of suitable input friction parameters for the DEM. All procedures mentioned in this article can lead to clarification of validation or calibration, thus facilitating development and design of new equipment with application of DEM in the future.*

*Keywords: Discrete Element Method (DEM), friction measurement, angle of static friction, rolling friction, restitution, input parameters*

## Introduction

In laboratory conditions and with application of modern equipment, the basic input parameters for DEM applications are detected, including friction of materials, bouncing of particles from the surfaces of materials used in transport or storage equipment, etc. [1-5]. These individual parameters, however, should be regarded a collection of properties, which can mutually interact; as a consequence, the absolute value of these individual parameters [5-6] is not quite determined. The complexity in determination and application of the complete collection of the measured values in DEM is further increased by the diverse shapes of the particles [5]. In each transportation and storage process, the different input parameter of the transported material's mechanical-physical properties plays a different role. For application of the DEM, it is necessary to know the equipment on which the method will be applied in terms of determination of the main control parameter with the most significant impact on the transport in the particular equipment [5-7]. We can consider optimization of the DEM input

parameters to make the resulting image of the material's behaviour resemble the real material [5-6, 8]. It can only be achieved by means of a suitable calibration of the material's input parameters [9-12]; then it is possible to satisfactorily simulate processes in the transport equipment during the transport process [13]. In thus adjusted simulation, it is also possible to detect critical conditions of the transport and use this knowledge in the design of the equipment [13-15].

## Experiments

They always depend on the particular transport system, so the considerations on the friction should be applied to the individual transport systems differently [2].

### *Determination of the coefficient of restitution*

According to [16], the coefficient of restitution is mathematically described as the square root of the proportion between the first bounce  $h_1$  [mm] and the height of the first landing of the particle  $H_1$  [mm] on the base, as illustrated in Fig. 1. The

landing of the plastic ball particles on various base materials was measured in the Laboratory of Bulk Materials VSB-TUO. The actual measurement was recorded by a high-speed camera Olympus I-speed 2 and evaluated by the supplied software. In this way, it is possible to acquire very accurate data on the motion and trajectory of the individual particle.

**Determination of the static friction coefficient**

A condition for application of the DEM is

knowledge of the static friction coefficient [5], which can be obtained for example from basic experiments on an inclined surface [3, 6, 17], as illustrated in Fig. 2. During the measurement, the surface with the contact material was inclined to reach an angle when the body started to move down the tested contact material. The coefficient of static friction between the moving body and the contact material was obtained through a tangent of the angle when the body

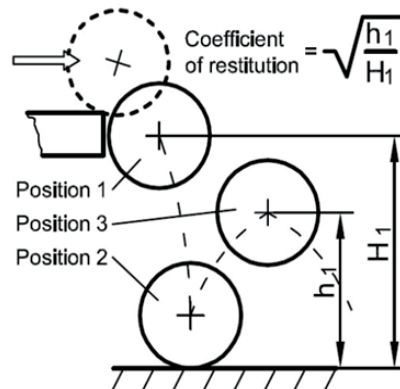

Fig. 1. Determination of the coefficient of restitution

Rys. 1. Określenie współczynnika restytucji

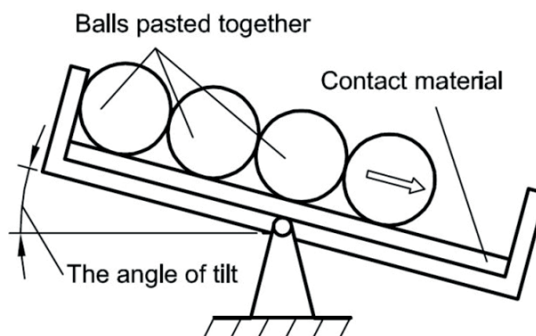

Fig. 2. Determination of the static friction angle

Rys. 2. Określenie kąta tarcia statycznego

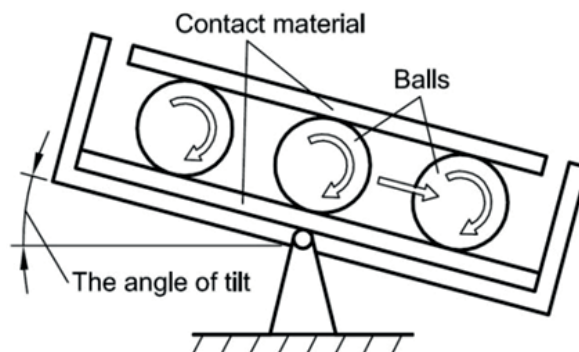

Fig. 3. Determination of the rolling friction angle

Rys. 3. Określenie kąta tarcia toczącego

started to move down the inclined surface. To achieve a mere slide of the spherical particles along the contact base, it was necessary to prevent rotation of the spherical particles. For this reason, two samples of glued spherical particles with different amounts were created. The measured values can be used as the limits or the medium values.

#### ***Determination of the rolling friction coefficient***

Another important input parameter for the DEM application is the rolling friction coefficient [5, 6, 17]. The principle of the measurement was based on detection of the contact plate's movement on the top of mutually separated ball particles along an inclined surface. The angle when the contact plate started to move was measured -

Fig. 3. It was necessary to use two plates from an identical contact material in the experiment. The experiment involved a sandwich arrangement of two contact plates, one fixed and the other moveable, and three spherical particles located between these samples of the contact material. The course of the moveable contact plate was limited by stoppers in the direction of the desired movement, i.e. in the direction of the incline. The measurement proceeded in both directions of rotation with a fixed plate of the contact material. Material deformation of the ball particles in this arrangement was considered negligible, so the angle of the surface was determined at the point when the top contact plate started to move and the rolling friction coefficient was calculated through the tangent of the angle.

Tab. 1. Parameters determined from measurements for obtaining the coefficient of restitution in a plastic spherical particle

Tab. 1. Parametry określone na podstawie pomiarów w celu określenia współczynnika restytucji w plastycznych cząsteczkach kulistych

Contact material	Height of the landing [mm]	Height of the bounce [mm]	Coefficient of restitution
Steel	32.92	22.31	0.82
Glass	32.31	28.01	0.93
Plastics	32.45	7.54	0.48
Plexiglass	32.56	23.53	0.85

Tab. 2. Parameters detected from measurements of the angle of static friction in plastic spherical particles

Tab. 2. Parametry odnotowane z pomiarów kąta tarcia statycznego w plastycznych cząsteczkach kulistych

Contact material	Average friction angle [deg]	Measurement deviation [deg]	Static friction coef.
Steel	19.7	±2.1	0.36 ± 0.0367
Plexiglass	22.1	±1.5	0.41 ± 0.0262
Plastics	16.5	±1.1	0.3 ± 0.0192
Glass	17.9	±1.7	0.32 ± 0.0297

Tab. 3. Parameters detected from measurements of the angle of rolling friction in plastic spherical particles

Tab. 3. Parametry odnotowane z pomiarów kąta tarcia toczącego w plastycznych cząsteczkach kulistych

Contact material	Average friction angle [deg]	Measurement deviation [deg]	Rolling frict. coef.
Steel	0.73	±0.062	0.013 ± 0.0011
Glass	0.26	±0.026	0.005 ± 0.0005
Plexiglass	0.32	±0.02	0.006 ± 0.0003
Plastics	1.26	±0.17	0.022 ± 0.003

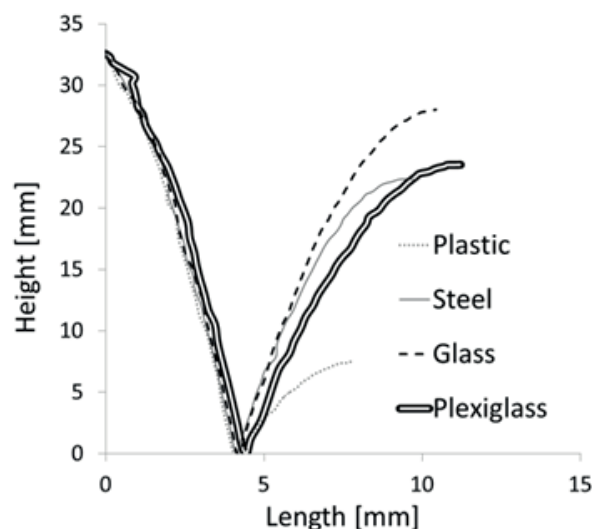

Fig. 4. Comparison of the bounce curves of a particle recorded by a high-speed camera

Rys. 4. Porównanie krzywych odbicia cząsteczek nagranych przez kamerę o wysokiej prędkości

### Outcomes of the experiments and discussion

Experiments focused on determination of the coefficient of restitution and static and rolling friction were performed using plastic spherical particles with the diameter of 6 mm, which are used in airsoft guns. The coefficient of restitution was determined between the spherical plastic particle and plates from steel, glass, plastic and plexiglass. The same contact materials were used for measurement of static coefficient of friction and rolling friction.

### Coefficient of restitution

In the first phase, a sequence of frames with landings of the plastic particle was recorded; the camera Olympus speed was set to at least 1,000 frames per second. By application of tracing, the recorded and stored video was used for determination of the course of a single particle in the X and Y system of coordinates. After creating the system of coordinates and calibrating the amount of pixels on the millimetre units, the data obtained from tracing of one spherical ball were exported to Microsoft Excel.

For a summary of the measured values, see Table 1 and summary of the recorded particle's bounce in Fig. 4. The coefficient of restitution for the particular materials was calculated using a method illustrated in section 2.1, Fig. 1.

### Coefficient of static friction

The static friction coefficient was measured between four contact materials and plastic spherical particles, see Table 2. To prevent their rotation, the particles were secured by gluing a certain

number of these particles in one plane, see Fig. 2. For a summary of the outcomes, see Table 2.

### Rolling friction coefficient

The measured values in Table 3 suggest that the worst material is the plastic, which should represent properties of the plastic spherical particles. The values are high, because this material has the lowest hardness from the series of the tested samples. This statement is also clear from comparison of the bounce courses of the particle recorded by a high-speed camera, see Fig. 4, where the coefficient of restitution was the lowest for the plastics.

### Conclusions

Measurement of the friction parameters is significantly affected by the roughness of the tested surfaces. The manufacturing process of the plastic spherical particles is not completely known. These balls are used as bullets for airsoft guns and the manufacturing companies protect their manufacturing processes. It is possible that these particles are hardened by ingredients, which affect their properties. The methods of the measurements explained in this article lead to a sufficient determination of these particles' properties, which cannot be simply determined, but which are sufficient for the DEM application in this condition.

### Acknowledgements

This paper was elaborated in the framework of the New creative teams project in priorities of scientific research, reg. no. CZ.1.07/2.3.00/30.0055, supported by Operational Programme Education

for Competitiveness and co-financed by the European Social Fund and the state budget of the Czech Republic.

This paper was supported by research projects of the Ministry of Education, Youth and

Sport of the Czech Republic: the Centre ENET CZ.1.05/2.1.00/03.0069.

Received February 12, 2014; reviewed; accepted April 9, 2015.

### Literatura - References

1. Zegzulka, J.: *The angle of internal friction as a measure of work loss in granular material flow*, *Powder Technology*, Volume 233, January 2013, p. 347–353.
2. Schwedes, J.: *Review on testers for measuring flow properties of bulk solids*, *Granular Matter*, Volume 5, Issue 1, May 2003, p. 1–43.
3. Scieszka, S. F., Adamecki, D.: *The importance of wall friction between particulate solids and elastic belt*, *Powder Technology*, Volume 245, Issue 1, September 2013, p. 199–207.
4. Mellmann, J., Hoffmann, T., Fürll, Ch.: *Mass flow during unloading of agricultural bulk materials from silos depending on particle form, flow properties and geometry of the discharge opening*, *Powder Technology*, Volume 253, Issue 1, February 2014, p. 46–52.
5. Höhner, D., Wirtz S., Scherer, V.: *Experimental and numerical investigation on the influence of particle shape and shape approximation on hopper discharge using the discrete element method*, *Powder Technology*, Volume 235, February 2013, p. 614–627.
6. Barrios, G. K. P., Carvalho, R. M. D., Kwade, A., Tavares, L. M.: *Contact parameter estimation for DEM simulation of iron ore pellet handling*, *Powder Technology*, Volume 248, November 2013, p. 84–93.
7. Komossa, H., Wirtz, S., Scherer, V., Herz, F., Specht, E.: *Transversal bed motion in rotating drums using spherical particles: Comparison of experiments with DEM simulations*, *Powder Technology*, Volume 264, September 2014, p. 96–104.
8. Alonso, C. P., Delgadillo, J. A., Scherer, V., Herz, F., Specht, E.: *Experimental validation of 2D DEM code by digital image analysis in tumbling mills: Comparison of experiments with DEM simulations*, *Minerals Engineering*, Volume 25, Issue 1, January 2012, p. 20–27.
9. Coetzee, C. J., Nel, R. G.: *Calibration of discrete element properties and the modelling of packed rock beds*, *Powder Technology*, Volume 264, September 2014, p. 332–342.
10. Coetzee, C. J., Els, D. N. J.: *Calibration of granular material parameters for DEM modelling and numerical verification by blade–granular material interaction*, *Journal of Terramechanics*, Volume 46, Issue 1, February 2009, p. 15–26.
11. Wensrich, C. M., Katterfeld, A.: *Rolling friction as a technique for modelling particle shape in DEM*, *Powder Technology*, Volume 217, Issue 1, February 2012, p. 409–417.
12. Grima, A. P., Wypych, P. W.: *Investigation into calibration of discrete element model parameters for scale-up and validation of particle–structure interactions under impact conditions*, *Powder Technology*, Volume 212, Issue 1, September 2011, p. 198–209.

13. Jovanović, A., Pezo, M., Pezo, L., Lević, L.: DEM/CFD analysis of granular flow in Static mixers, *Powder Technology*, Volume 2012, Issue 1, November 2014, p. 240–248.
14. Cleary, P. W.: Particulate mixing in a plough share mixer using DEM with realistic shaped particles, *Powder Technology*, Volume 248, Issue 1, November 2013, p. 103–120.
15. Coetzee, C. J., Els, D. N. J.: The numerical modelling of excavator bucket filling using DEM, *Journal of Terramechanics*, Volume 46, Issue 5, October 2009, p. 217–227.
16. Bharadwaj, R., Smith, C., Hancock, B. C.: The coefficient of restitution of some pharmaceutical tablets/compacts, *International Journal of Pharmaceutics*, Volume 402, Issue 1-2, December 2012, p. 50–56.
17. Mack, S., Langston, P., Webb, C., York, T.: Experimental validation of polyhedral discrete element model, *Powder Technology*, Volume 214, Issue 3, December 2011, p. 431–442.

### Sposób ustalania parametrów wejściowych dla Metody Elementów Dyskretnych

Ten artykuł opisuje możliwości pomiaru właściwości mechanicznych i fizycznych masy cząstek stałych, które mogą być wykorzystane do walidacji i kalibracji DEM, a służy również do definiowania podstawowych parametrów wejściowych, lub ich zakresów. Walidacja może być przeprowadzona za pomocą realistycznego modelu urządzenia, który porównuje się z modelem DEM. Dalej oto lista możliwych procedur pomiaru realistycznego materiału prowadzące do identyfikacji i weryfikacji właściwości parametrów wejściowych dla DEM. Jako materiał walidacji mogą być stosowane plastikowe kuliste cząstki, ponieważ ten kształt stanowi zasadniczą cząstkę dla DEM. Wyznaczanie współczynnika restytucji jest realizowany za pomocą kamery o wysokiej prędkości, a następnie mierzy się ścieżka ruchu cząstek w jednej płaszczyźnie XY. Zbieranie danych pomiarowych jest używany do identyfikacji i doboru odpowiednich parametrów wejściowe tarcia dla DEM. Wszystkie procedury wymienione w tym artykule może doprowadzić do wyjaśnienia problemów walidacji i kalibracji, i w ten sposób ułatwić rozwój i projektowanie nowych urządzeń w przyszłości przy użyciu DEM.

Słowa kluczowe: Metoda Elementów Dyskretnych (ang. Discrete Element Method skr. DEM), pomiar tarcia, kąt tarcia statycznego, tarcie obrotowe, tarcie toczne, restytucja, parametry wejściowe